



ROURA

Distributed By:
Solution Dynamics Inc
877-860-3620

RUGGED HOPPER MODEL

2T-3/16-105 1/3 CU YD



MODEL #	SIZE	L	W	H	LH	FORK OPENING	WEIGHT	CAPACITY
2T-3/16-105	1/3 CU YD	49 1/2"	32"	31"	28 1/2"	2 1/2" X 21"	352 LBS	4000 LBS

RUGGED 2T-3/16-105

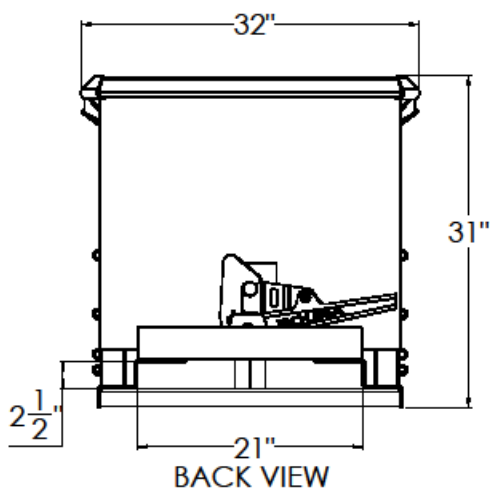

BACK VIEW

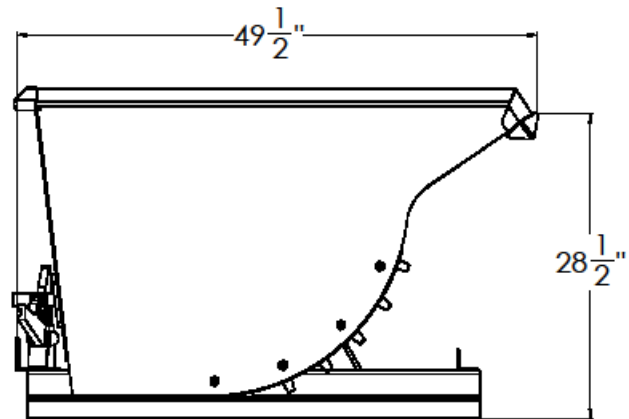

SIDE VIEW

CONSTRUCTION: 7 gauge plate body and 3/16" formed plate base. Bodies are 100% continuous weld for superior construction. Ductile iron handle, standard stops and secure flip latch are standard on this model.

FINISH: Bright safety green enamel paint (other colors optional).

OPTIONAL ITEMS ARE AVAILABLE

"FOR ALL YOUR MATERIAL HANDLING NEEDS!"