



ROURA

Distributed By:
Solution Dynamics Inc
877-860-3620

DURABLE HOPPER MODEL

1T-12-SL-1/2 1/2 CU YD



MODEL #	SIZE	L	W	H	LH	FORK OPENING	WEIGHT	CAPACITY
1T-12-SL-1/2	1/2 CU YD	47"	51 1/2"	24"	24"	2 1/2" X 28 3/4"	324 LBS	2000 LBS

DURABLE 1T-12-SL-1/2

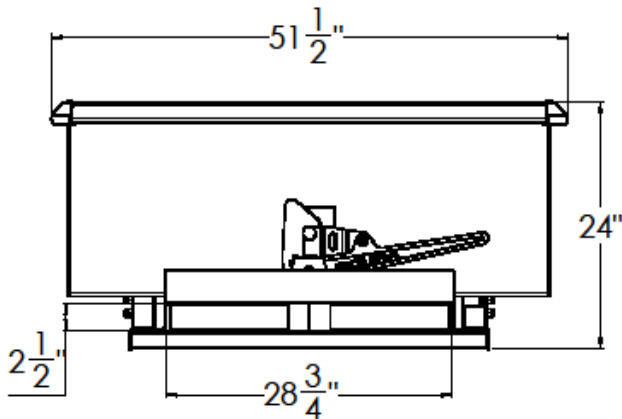

BACK VIEW

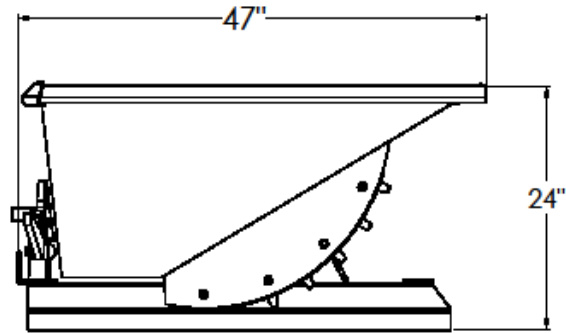

SIDE VIEW

CONSTRUCTION: 12 gauge plate body and 3/16" formed plated base. Bodies are 100% continuous weld for superior construction. Ductile iron handle, standard stops and secure flip latch are standard on this model.

FINISH: Bright safety green enamel paint (other colors optional).

OPTIONAL ITEMS ARE AVAILABLE

"FOR ALL YOUR MATERIAL HANDLING NEEDS!"