

Foster

Distributed by:
Solution Dynamics Inc
PH: 877-860-3620
www.sodyinc.com

ON-A-ROLL LIFTER® COMPACT

Designed specifically for sign makers and other businesses with the need to handle heavy media rolls. It enables users to quickly and effortlessly lift media as heavy as 200 lbs (90 kg) and as wide as 71 inches (1800 mm), with diameters as great as 12 inches (30.5 cm). The compact design allows user to maneuver around tight corners and through narrow passages.

NEW
COMPACT
DESIGN!



IMPORTANT FEATURES

- Easy-to-use operation reduces on-the-job injuries
- User-friendly operation avoids costly and dangerous handling mistakes that damage media
- Single-person operation saves labor and time
- Designed to operate even in shops with limited floor space
- Rugged construction ensures long lifter life

MODEL 61579

Roll Weight Capacity.....	90 kg (200 lbs)
Lift Height	85 cm (33.5")
Max. Roll Width	180 cm (71")
Max. Roll Diameter	30.5 cm (12")
Width x Depth.....	57.4 cm x 79.6 cm (22.6" x 31.34")
Height.....	107.9 cm (42.48")
Weight.....	80 kg (177 lbs)
Bottom Fork Clearance	11.7 cm (4.63")

2-year warranty on all wheels, hydraulics and media tray.
5-year warranty on cross bars.



ON-A-ROLL LIFTER® COMPACT MODEL 61579

Tight corners? Narrow spaces?
This lifter goes where others cannot.

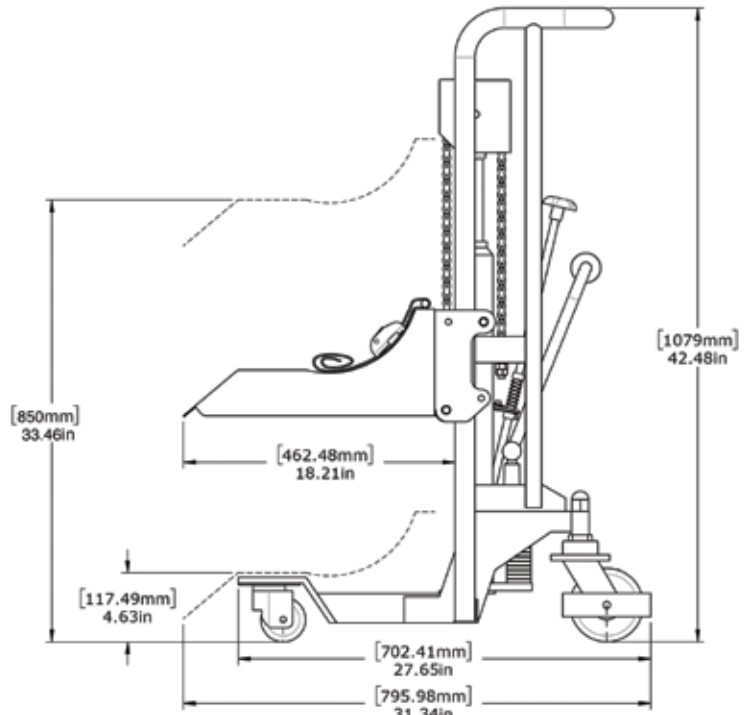
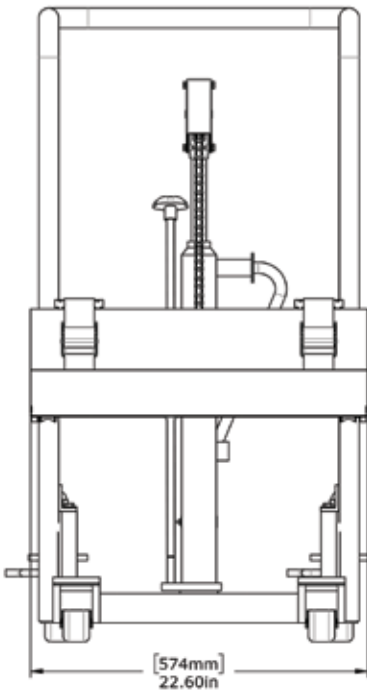
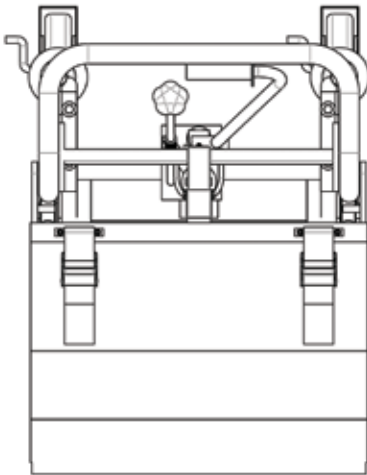

toll free (USA and Canada only) 877-860-3620 or 262-521-5730 • fax 262-521-5733

Solution Dynamics Inc • www.sodyinc.com