



# PDSR30

## Power Steering Walkie Reach Truck



### CAPACITY

3000 lbs. at 24" load center

### BATTERY COMPARTMENT

31.6" x 9.06" x open.  
Anderson 175 Gray—A-11  
Minimum battery weight 550 lbs.

### SPEED

ZAPI travel controller

### TRAVEL

Variable from 0 mph to 3.4 mph empty  
Variable from 0 mph to 3.1 mph loaded

### LIFT

Up to 40 fpm empty.  
Up to 35 fpm loaded—3000lbs

### LOWERING

Up to 29 fpm empty.  
Up to 57 fpm loaded—3000lbs

### WEIGHT

3,690-3,980lbs Chassis Only

### TIRES / WHEELS

DRIVE  
10" x 4" polyurethane  
DUAL LOAD  
(2) 4" x 2.75" polyurethane

### HYDRAULICS

Lift cylinder has hard chrome plated rods. Pump unit including motor, solenoid, gear pump, and pressure compensated lowering valve are mounted high in the power compartment for ease of service.

### ELECTRICAL

24-Volt ZAPI AC O inverter, travel control with matching drive motor provide high performance throughout the entire speed range. Travel speed remains constant relative to throttle position regardless of load. Separately fused power control circuits, quick disconnect EPD power cut off, and hour meter / battery discharge indicator combination gauge complete the system. Power configurations and diagnostic features are displayed with a ZAPI handheld console.

### BRAKES

Regenerative electromagnetic brake is mounted on the motor armature shaft multiplying the braking power through the transmission.

Brake is applied when the control arm is in the vertical or horizontal handle position. Travel speed is reduced when forks are above 12" fork height. Neutral braking resists roll back on ramps.

### CONTROLS

Travel, lift, and lower functions are located in the ergonomic operator handle. All operator controls are accessible without having to lift the hand from the handle.

Angle grips are designed to allow easy operation with either hand. Wrap around guard, reversing switch, thumb control, and horn are standard.

Top mounted tiller arm offers excellent operator comfort and minimum steering effort. Gas assisted spring gently returns handle to vertical position.

### TRANSMISSION

Vertically mounted drive motor is direct mounted to gear housing. Oil bathed ZF GK10 hypoid bevel gear drive train with tapered roller bearings transfers power to axle. State of the art optimized gear technology supplies advantages such as minimal envelope circle, zero maintenance, low noise level, high efficiency and high performance.

### MAST & PANTOGRAPH

I-beam mast with dual lifting chains. Pantograph stroke extends the fork carriage beyond the units straddle legs, with integral tilt and sideshift.

### STRADDLE LEGS & FORKS

Fixed straddle leg inside dimensions (ID) available at 34" or 42" resulting in a 42" or 50" outside dimension (OD)

Class two ITA fork carriage with 36" tall load back rest. 42" Forks are adjustable.

### BEARINGS

Drive Wheels: Tapered roller bearings sealed in oil bath  
Load Wheels: Sealed ball bearings

### ACCESSIBILITY

Removal of two piece power head cover exposes major components for inspection and maintenance

### STANDARD EQUIPMENT

- Power Steering
- Pantograph with Sideshift and Tilt
- Proportional Lift, Lower & Extend
- Regenerative Neutral Braking
- Low Battery – Interrupt
- Hour Meter BDI Combo Gauge
- Key Switch

### OPTIONAL EQUIPMENT

- 10" Single Load Wheel
- Straddle ID/OD of 34/42 or 42/50
- ClearView Polycarbonate Mast Guard
- 224 AH AGM Battery Pack w/110V charger
- Industrial Battery 255 AH with External Charger

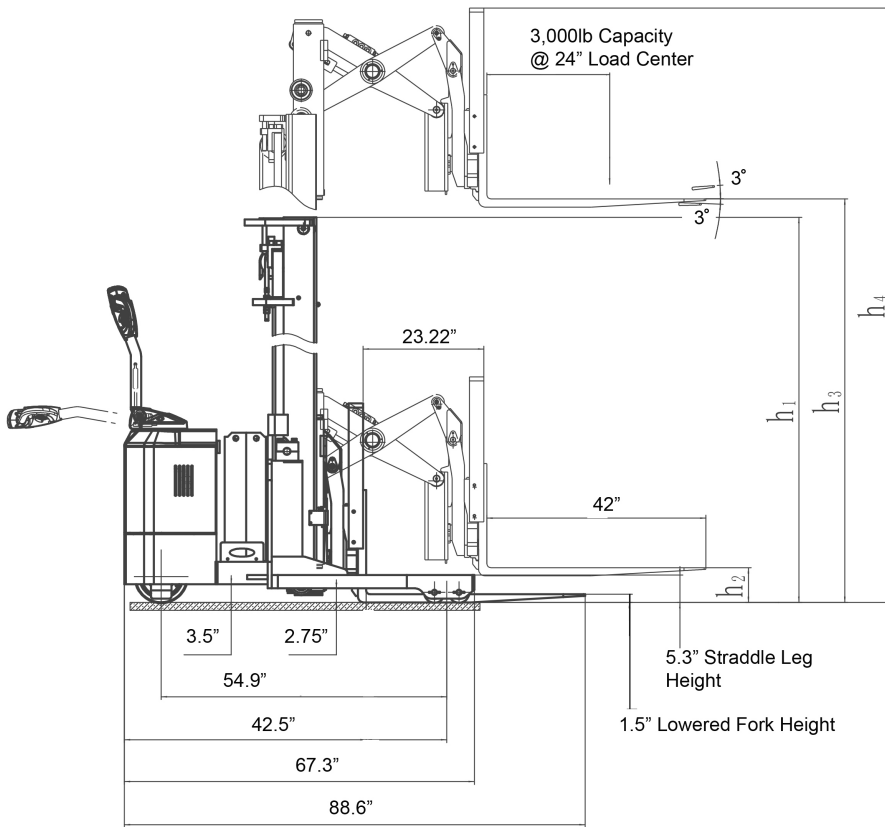

### Aisle Guide

PDSR30 Right Angle Stack Dimensions

Load Size	36" Length	40" Length	48" Length
36" Width	79.5"	79.5"	79.5"
40" Width	81.0"	81.0"	81.0"
48" Width	85.3"	85.3"	85.3"

For ease of use add 8" to aisle dimension listed.

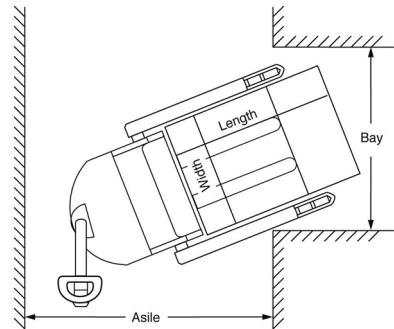

Aisle dimensions listed above assume the minimum bay width to be straddle OD plus 5" (2.5" on each either side of straddle leg). Truck performance may vary due to application re-quirements' and changes in model design.

Overall length increased by up to 3" when control handle is perpendicular to the direction of travel

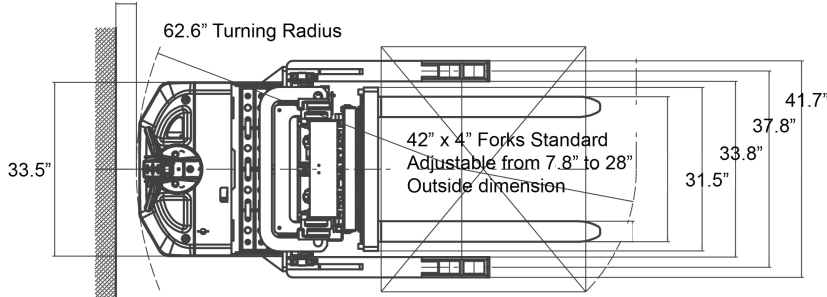

Truck Model 24" Load Center	Straddle ID/OD	Mast Type	Lift Height (h3)	Collapsed Height (h1)	Free Lift (h2)	Extended Height (h4)	<sup>3</sup> Weight (lbs)	
<b>3000 lbs. Capacity</b>								
PDSR30-106	34/42 or 42/50	Two Stage	106	76.5	6.5	144.25	3690	
PDSR30-126	34/42 or 42/50	Two Stage	126	83	6.5	166.75	3750	
PDSR30-157*	34/42 or 42/50	Three Stage	157	77.25	39.25	195.25	3980	

\*Derates 500lbs above 126"

<sup>3</sup> Estimated shipping weight without battery